

SYM	ECN NO	DATE	APPRVAL
△			

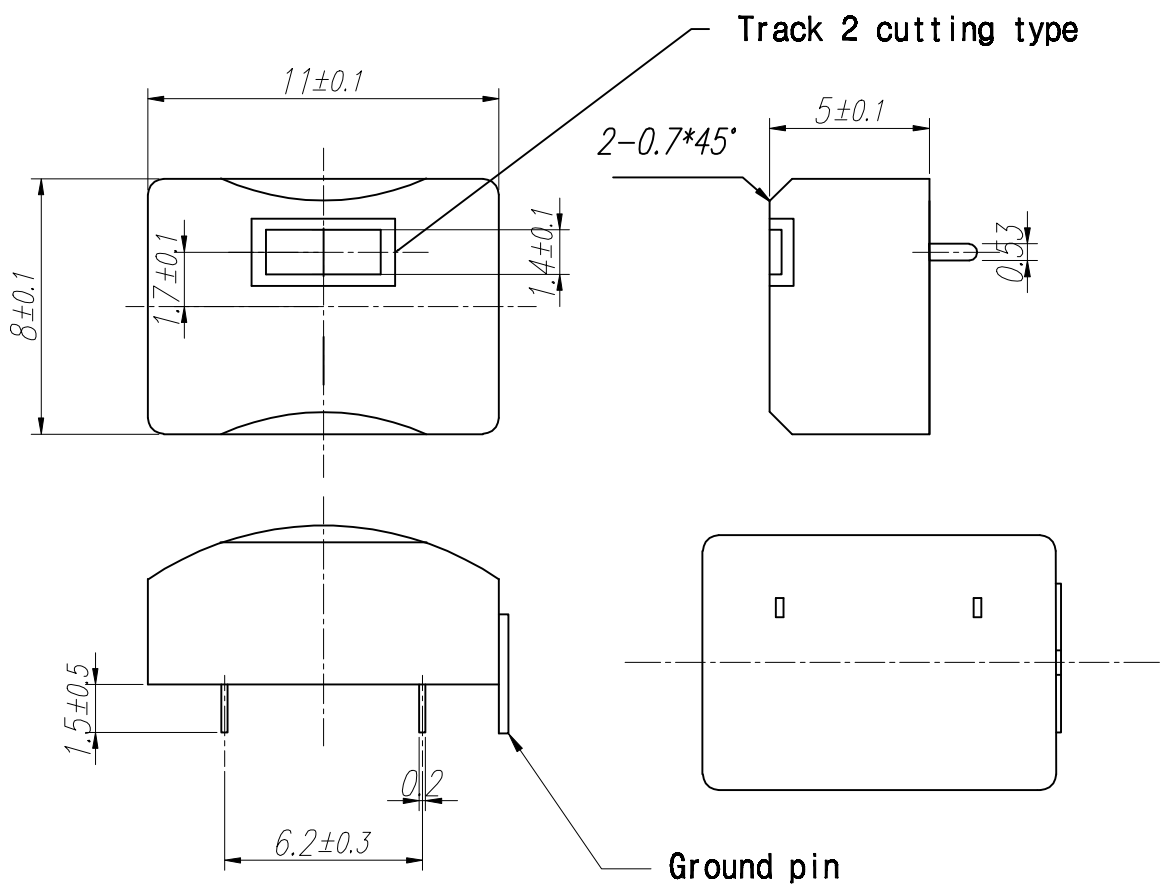

### Specification

Inductance	mH	28±30%	1KHz	100 μA
DC Resistance	Ω	140±25%	DC	at 20°
Recording Density	BPI	210		
Tape Speed	IPS	7.5	Measuring Tape	
Read Output	mVp-p	25±25%	PM50-78	
Insulation R	MΩ	50	250V DC	
Core Earth	Ω	100 Max	100 μA	
Gap Length	μm	12.5±6		
Track Width	mm	1.4±0.1		
Head Life	Times	500,000Min		

UNLESS OTHERWISE NOTED:  
 1) DIMENSIONS ARE IN MILLIMETERS  
 2) TOLERANCES:  
 .X ± .1  
 .XX ± .05  
 ANGLES ± 0°~30'

SCALE <sup>4</sup> / 1 MM REV A

CORE MATERIAL: PERMALLOY

MODEL Single head (5.0)

DWG. NO

2 TRK READ HEAD

**JINSUNG DIGITECH**

DWG DGN CHK APP

ZHC