

SYM	ECN NO	DATE	APPRVAL
△			

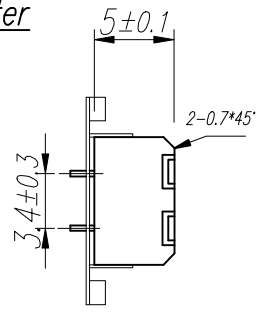

Red 51mm  
Red 45mm  
Black 56mm  
Blue 51mm  
Blue 45mm

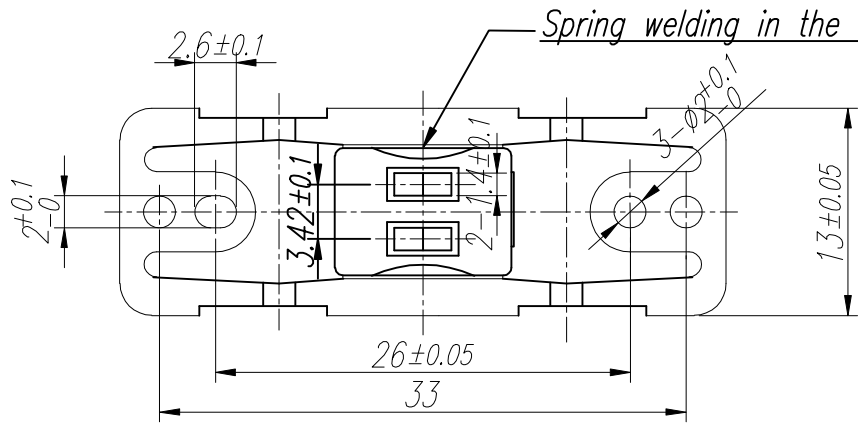
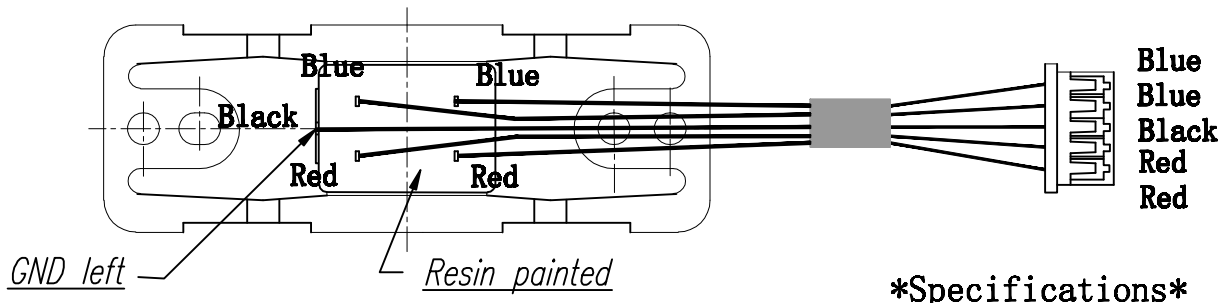
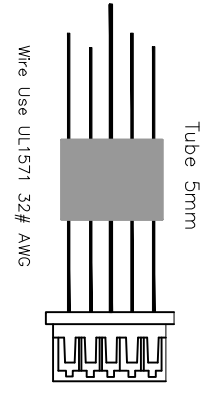
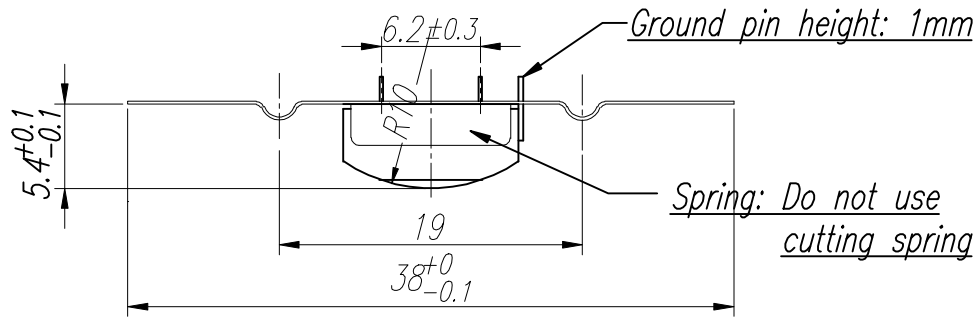

**\*Specifications\***  
 Inductance: 100mH ± 30%  
 DC Resistance: 220 Ω ± 25%  
 core material: permalloy  
 Spring thickness : 0.17mm  
 Welding height: 5/5.4mm  
 Cable: AWG32 normal cable

MATERIAL				Q'TY	1	FINISH	BARREL		
TOLERANCE	X.X = ±0.1			SCALE	2/1	MM	REV	A	
	X.XX = ±0.05								
			DATE						
DWG	DGN	CHK	APP	TITLE	2 TRKS READ HEAD				
ZHC				MODEL	JS 1060-50				
<b>JINSUNG DIGITECH</b>				DWG. NO	01808423				