

SYM △	ECN NO	DATE	APPRVAL
----------	--------	------	---------

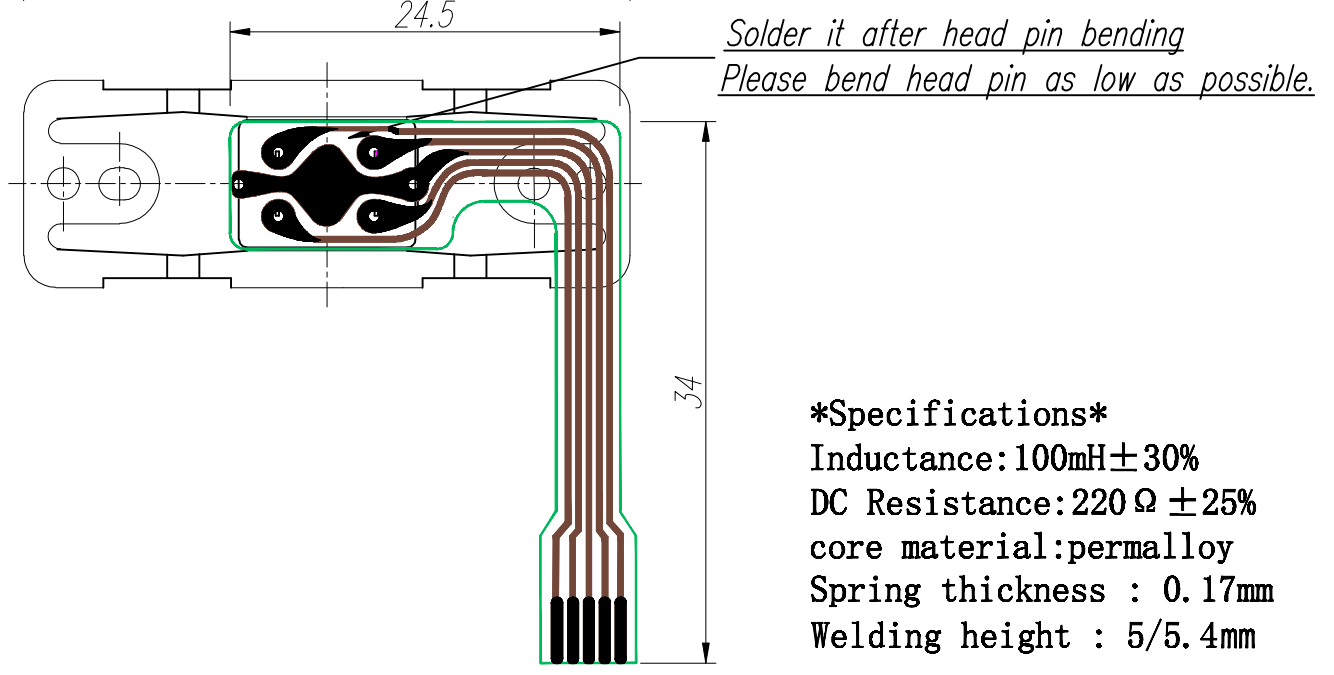
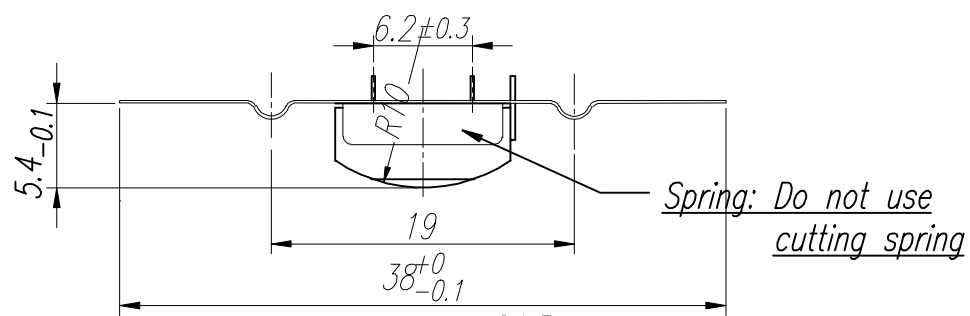
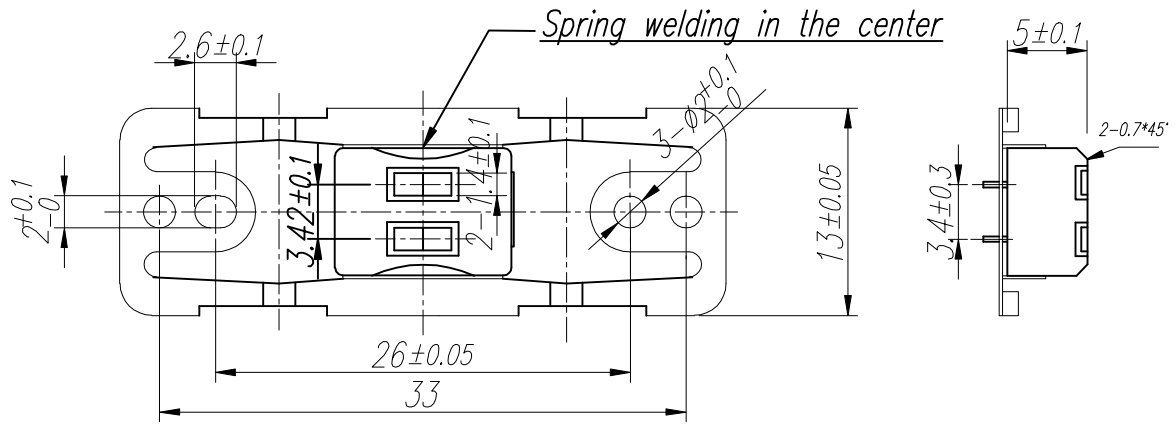

**\*Specifications\***  
 Inductance: 100mH ± 30%  
 DC Resistance: 220 Ω ± 25%  
 core material: permalloy  
 Spring thickness : 0.17mm  
 Welding height : 5/5.4mm

MATERIAL				Q'TY	1	FINISH		BARREL		
TOLERANCE X.X = ±0.1 X.XX = ±0.05 ANGLE =				SCALE	2/1	MM	REV	A		
				DATE						
DWG	DGN	CHK	APP	TITLE		2 TRKS READ HEAD				
ZHC				MODEL		JS 1060-FPCB				
<b>JINSUNG DIGITECH</b>				DWG. NO		01710423				